

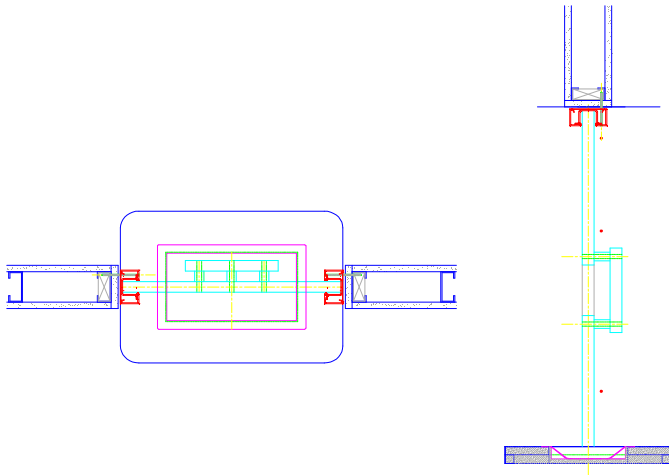

**-PBITW-  
INTERIOR TRANSACTION  
WINDOW**

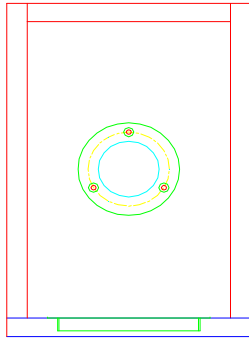

SECTION

Units can be easily attached together for multiple stations

**FEATURES**

- Available in bronze or clear anodized
- Black plastic laminate base 16 x 10 x 1-1/2"
- Delivered assembled & ready for installation
- Ships within 1 to 2 weeks
- Forced entry option available
- For interior applications
- For U.L. 752 levels 1, 2, & 3

**RECOMMENDED USES**

- Cash payment windows
- Reception/Interview windows
- Ticket windows

**AVAILABLE SIZES**

Standard Sizes		
24" x 36"	30" x 36"	30" x 42"
36" x 36"	36" x 42"	48" x 36"
48" x 42"	60" x 36"	60" x 42"
72" x 42"	72" x 36"	

**GLAZING MATERIAL OPTIONS**

<b>Level 1</b>	1-1/4" Acrylic 1-1/4" SAR Coated Acrylic 3/4" Lexgard MP750 1-3/16" BR Glass
<b>Level 2</b>	1-3/8" Acrylic Glass Clad Polycarbonate
<b>Level 3</b>	1-1/4" Polycarbonate Glass Clad Polycarbonate

**INSTALLATION DETAILS**

Finished opening should be 1/4" wider & 1/4" higher than the size of the unit.

- 1) Cut a finished opening in the wall sized to fit the standard PBITW Window.
- 2) Place a preframed PBITW Window opening, shim much as necessary and attach sides to existing wall with screws, using anchors if the wall is masonry.
- 3) Apply finish trim molding that can be obtained locally, and installation is complete.



## PBITW INTERIOR TRANSACTION WINDOW

### HANDLING INFORMATION

#### HANDLING:

Safety and care should be exercised during shipping and handling to maintain transaction window appearance.

#### APPLICATION:

Remove unit from protective container just prior to installation. Care and safety should be exercised when installing window to insure that the installation is level, square, plumb, and secure.

#### STORAGE:

Store product upright in a dry, well ventilated building or area at a consistent temperature. Do not store in damp areas or areas that are freshly plastered. Place product unit on wood blocks at least 2" high to prevent any moisture damage.

### CUSTOMER SERVICE

Pacific Bulletproof Co. maintains a complete staff of professional and experienced installers, sales representatives, engineers, designers, project estimators, and craftsman that are all ready to assist in all of the phases of your bullet resistant projects. From the initial design to the installation process. Contact your local representative for assistance for all your bullet resistant needs.

### SPECIFICATIONS

#### A. WINDOW CONSTRUCTION

- 1) This unit has an aluminum tubular deep capture frame with a plastic laminate base and recessed cash tray. Voice transmission is through a natural acrylic talk thru.
- 2) Standard base construction is a layered particle board with a plastic laminate covering and 3" radius rounded corners.
  - a) Deal tray is to be stainless steel, recessed and mortised into the laminate.

#### B. WINDOW GLAZING

- 1) All glazing materials shall be of a type listed by the Underwriter's Laboratories for bullet resistance and/or to be tested by the H.P. White Laboratory for specified bullet resistance.
- 2) Bullet resistance protection level shall be specified by the end user and be consistent with threat level.