

*** NOT TO BE DISTRIBUTED OR COPIED WITHOUT PRIOR CONSENT OF PACIFIC BULLETPROOF ***

PART #: PBAMBS
PROTECTION LEVEL: 1,2,3

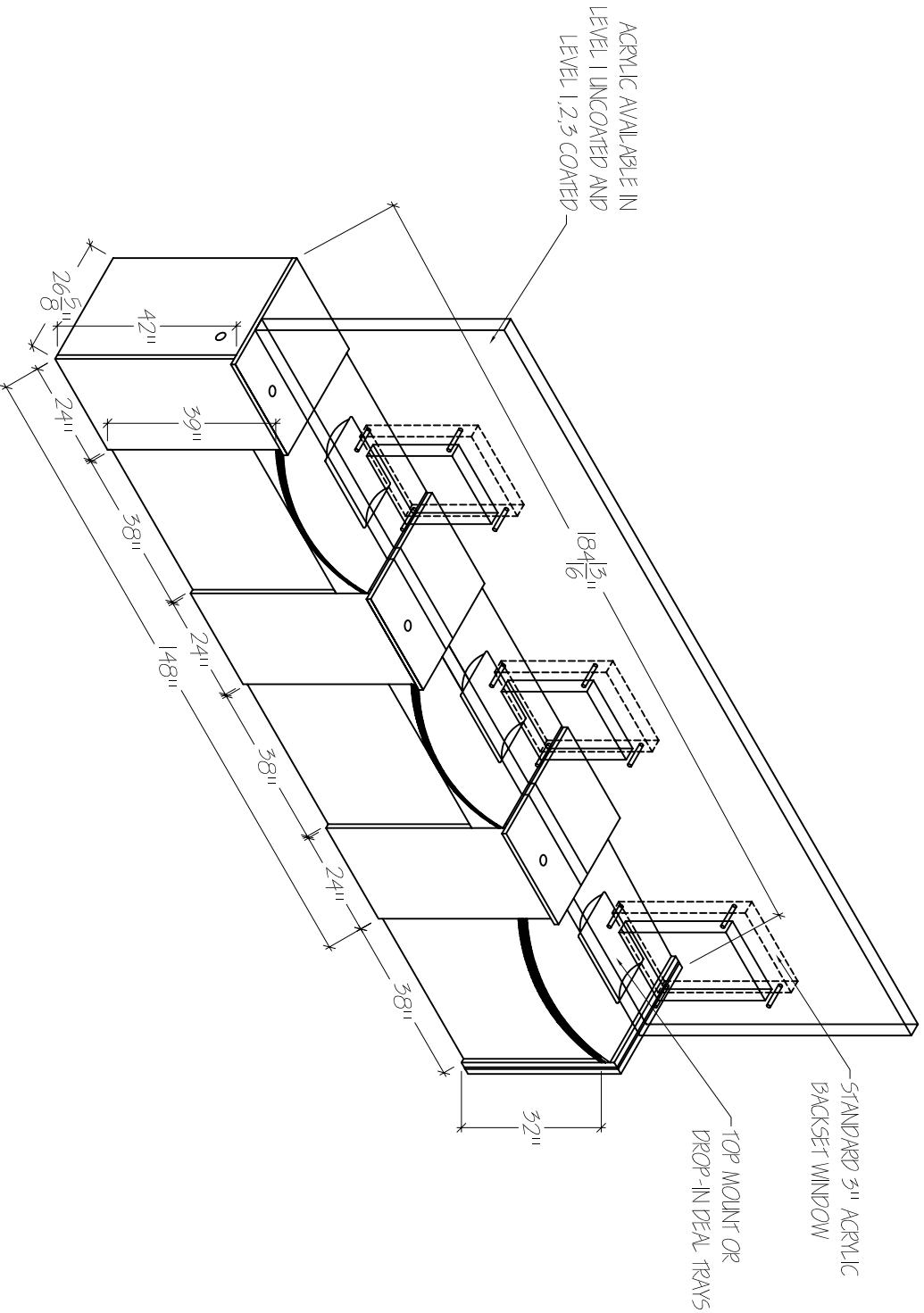

CUSTOMER APPROVAL:

CUSTOMER SIGNATURE

MANAGER APPROVAL:

DATE

PACIFIC BULLETPROOF SIGNATURE

PACIFIC BULLETPROOF CO.

Specializing in Ballistic Products & Systems
4035 Leaverton Court, Anaheim, Ca. 92807
www.pacificbulletproof.com Tel. (714)630-5447 Fax (714)630-5314

Project Name:
MODULAR COUNTER SYSTEM FLOATING BACKSETS BULLET RESISTANT PANEL INSTALLATION

Revision:
Revision:
Revision:

Drawn By: TC
Scale: NTS
Date: 10/12/06

Sheet No.
PW

*** NOT TO BE DISTRIBUTED OR COPIED WITHOUT PRIOR CONSENT OF PACIFIC BULLETPROOF ***