

PART #: PBWW7D

**1724 WW and 1728 WW Transaction**

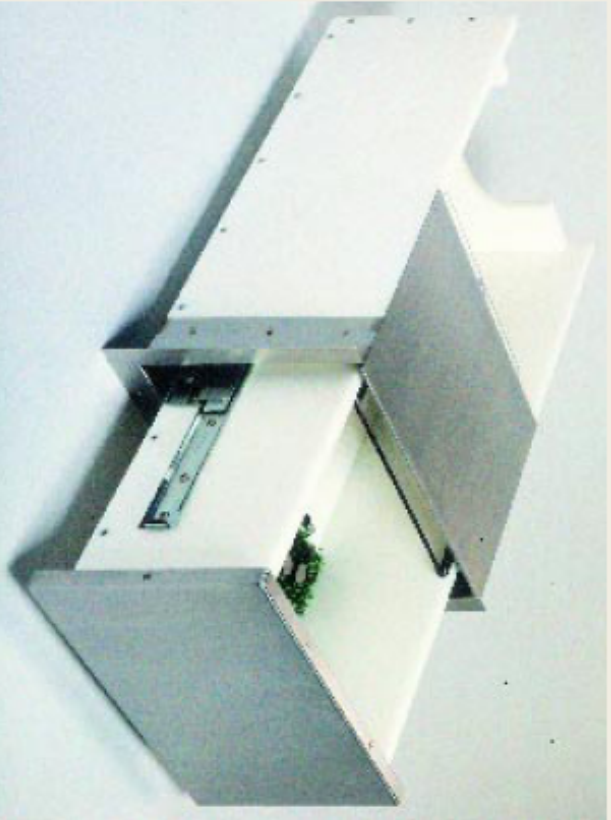

WW Series Transaction Drawer is designed with exterior walk-up service in mind. It has an extra deep stainless steel hood which enables it to fit thicker walls. The Lexan lid prevents direct entry of outside air while allowing clear view of drawer interior. Drawer movement is controlled by a large aluminum handle on rear. Front of unit is stainless steel. Easy operation is allowed by smooth running ball bearing extension sides.

Drawer is furnished with bill clip and brush type coin pad and locks with drop bolt through bottom of drawer into housing.

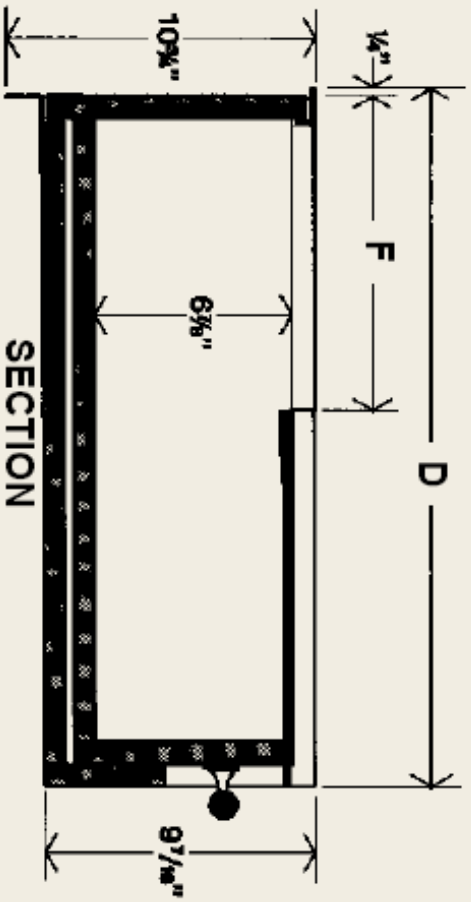

Model	DIMENSIONS	
	D	F
1724 WW	24 1/4"	11"
1728 WW	28 1/4"	15"

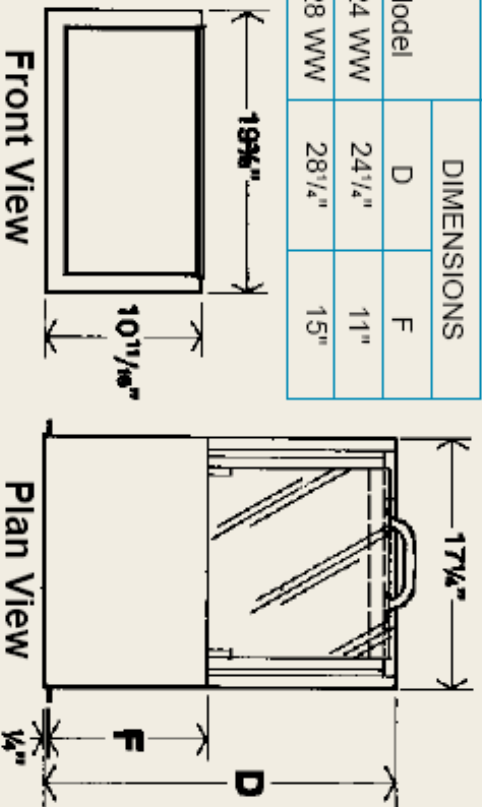

**CUSTOMER APPROVAL:**

CUSTOMER SIGNATURE

DATE

**MANAGER APPROVAL:**

PACIFIC BULLETPROOF SIGNATURE

**PACIFIC BULLETPROOF CO.**

Specializing in Ballistic Products & Systems  
 4035 Leaverton Court, Anaheim, Ca. 92807  
 www.pacificbulletproof.com Tel. (714)630-5447 Fax (714)630-5314

Project Name: **WW SERIES TRANSACTION DRAWERS**  
 BULLET RESISTANT PANEL INSTALLATION

Revision:   
 Revision:   
 Revision:

Drawn By: **TC**  
 Scale: **NTS**  
 Date: **08/21/06**

Sheet No. **PW**