

Shuresafe® Model 670183 Dual Purpose Security Drawer

Product Description

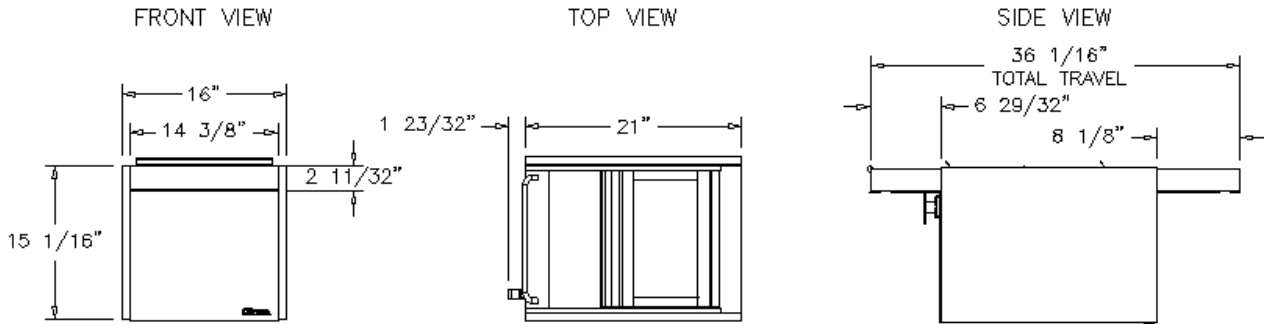

- ✓ Equipped with a sliding deal tray for low profile items, money, and credit card or document transactions.
- ✓ Large stationary pass-thru area for transferring bulkier items up to gallon sized containers, twelve-packs of canned products and other convenience store products.
- ✓ The deal tray slides full-length forward and backward, to control access to the fixed transfer area.
- ✓ Flexible design with four Models available to accommodate a variety of needs and applications.
- ✓ Optional WeatherGuard Frames are available for all four models with a frame that includes a Plexiglas cover and keeps environmental elements from entering the building and the drawer.
- ✓ Units are finished in brushed stainless steel and shipped with some assembly required.



Model	Overall Size			Frame Face		Transfer Area			Wall Opening		Wt.	Features
	W	H	L	W	H	W	H	L	W	H		
670183	16"	15 1/16"	21"	16"	15"	13 3/4"	11 5/8"	6 3/8"	16 1/4"	15 1/4"	85 lbs.	Optional Weather Guard

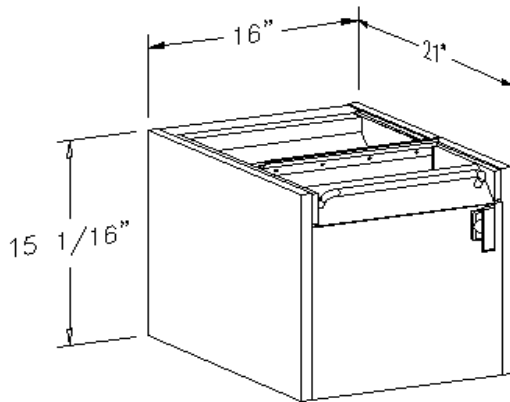

OPERATOR SIDE

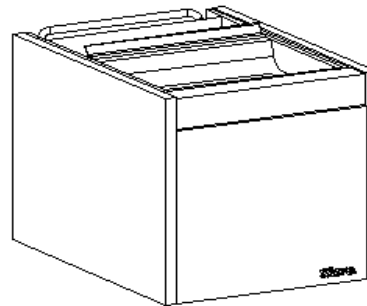

CUSTOMER SIDE