

Shuresafe® Model 670192 Dual Purpose Security Drawer

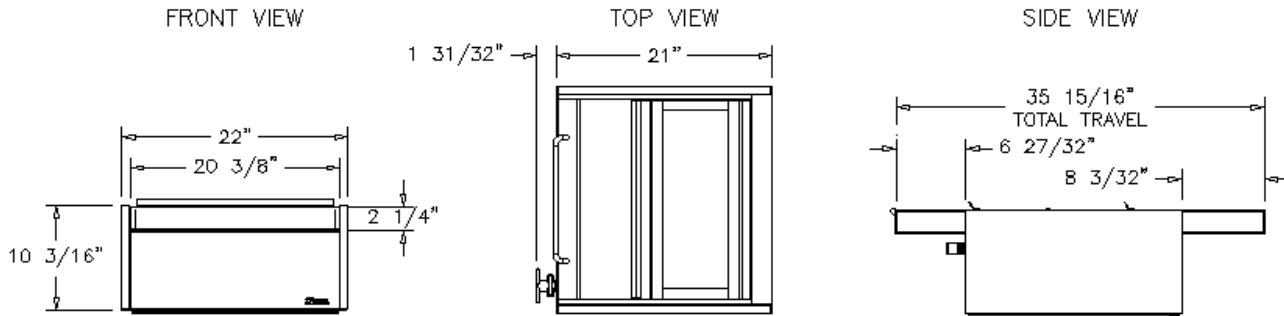

Product Description

- ✓ Equipped with a sliding deal tray for low profile items, money, and credit card or document transactions.
- ✓ Large stationary pass-thru area specifically designed for transferring canned products and take out or delivery pizza products.
- ✓ The deal tray slides full-length forward and backward, to control access to the fixed transfer area.
- ✓ Optional WeatherGuard Frame is available that includes a Plexiglas cover and keeps environmental elements from entering the building and the drawer.
- ✓ Units are finished in brushed stainless steel and shipped with some assembly required.



Model	Overall Size			Frame Face		Transfer Area			Wall Opening		Wt.	Features
	W	H	L	W	H	W	H	L	W	H		
670192	22"	10 3/16"	21"	22"	10"	19 1/2"	6 5/8"	6 3/8"	22 1/4"	10 1/4"	85 lbs.	Optional Weather Guard

